

Fig. 1

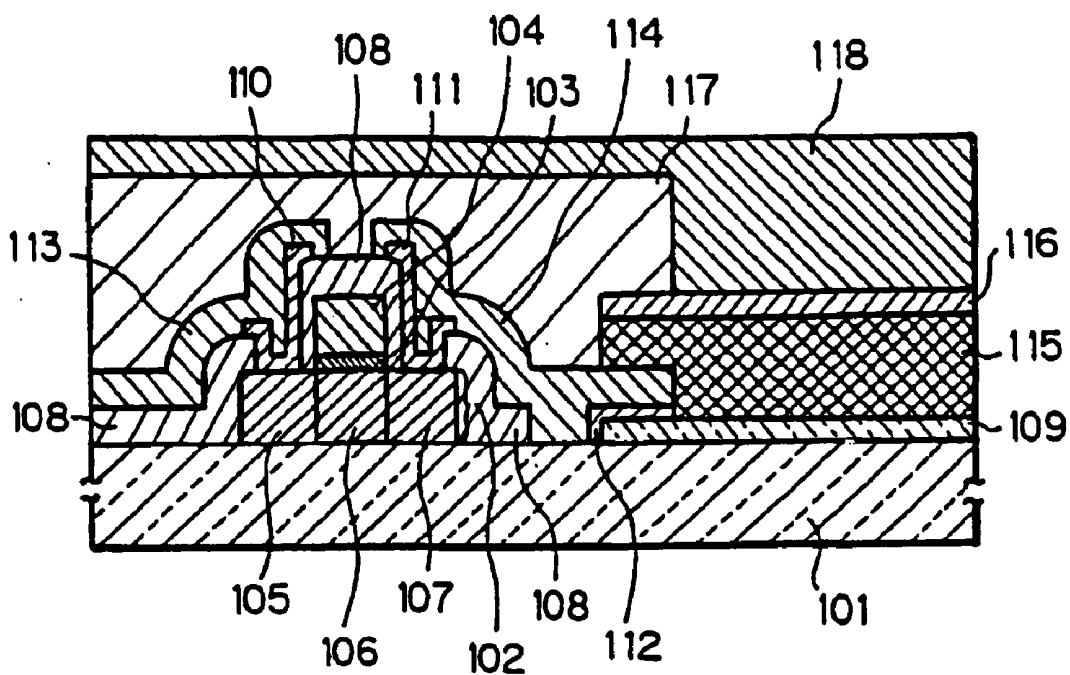
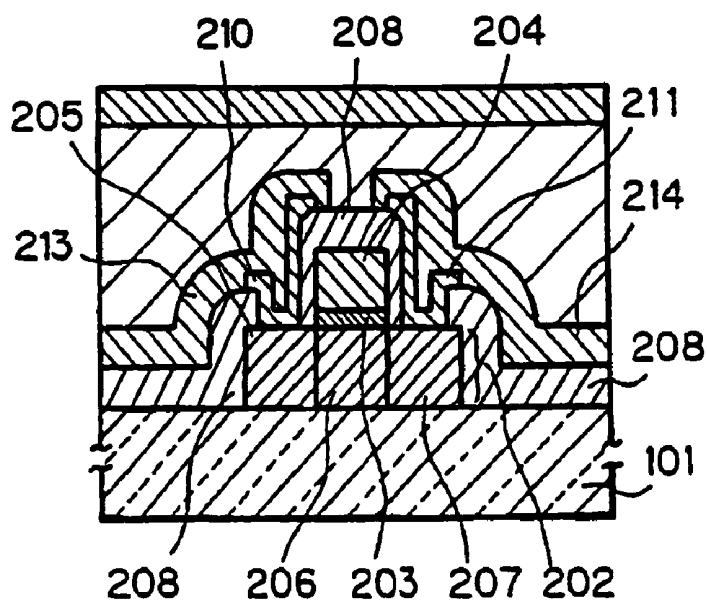
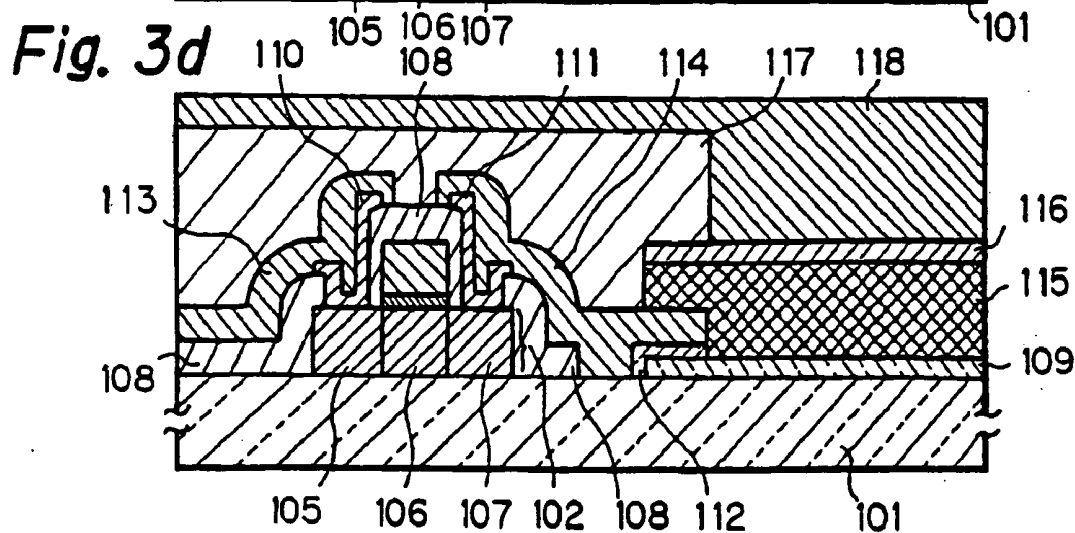
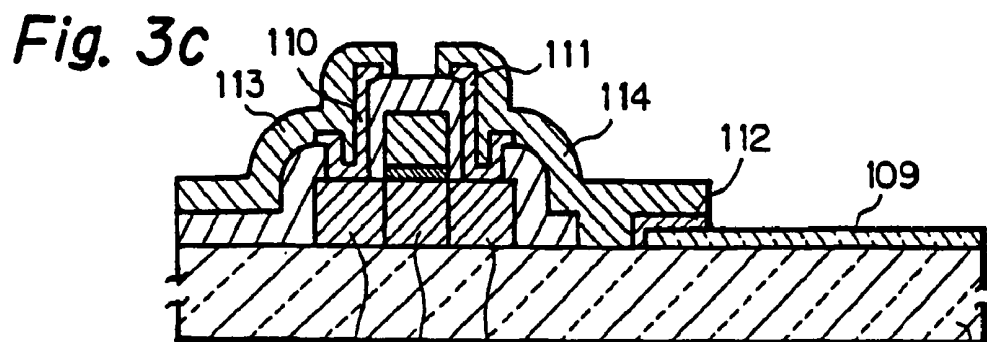
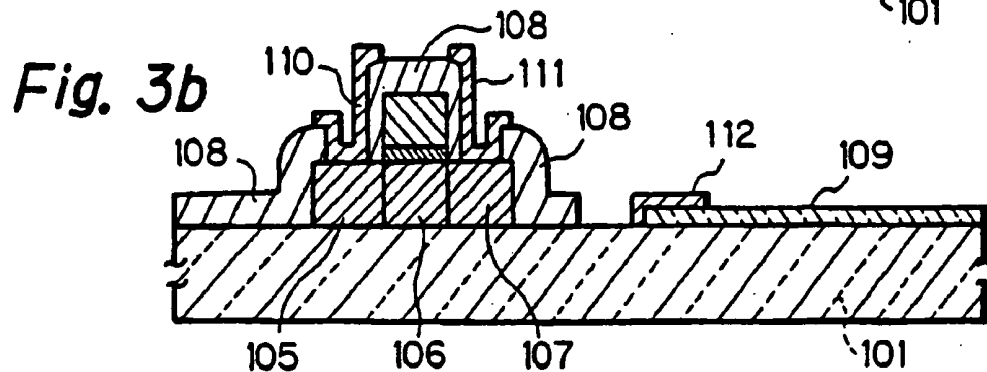
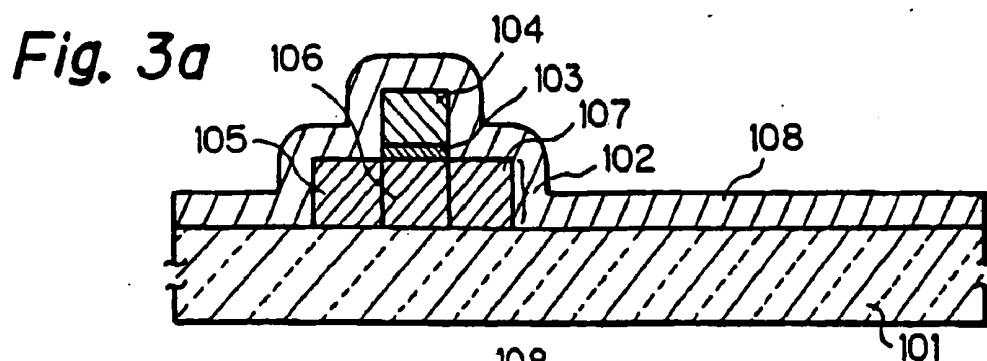
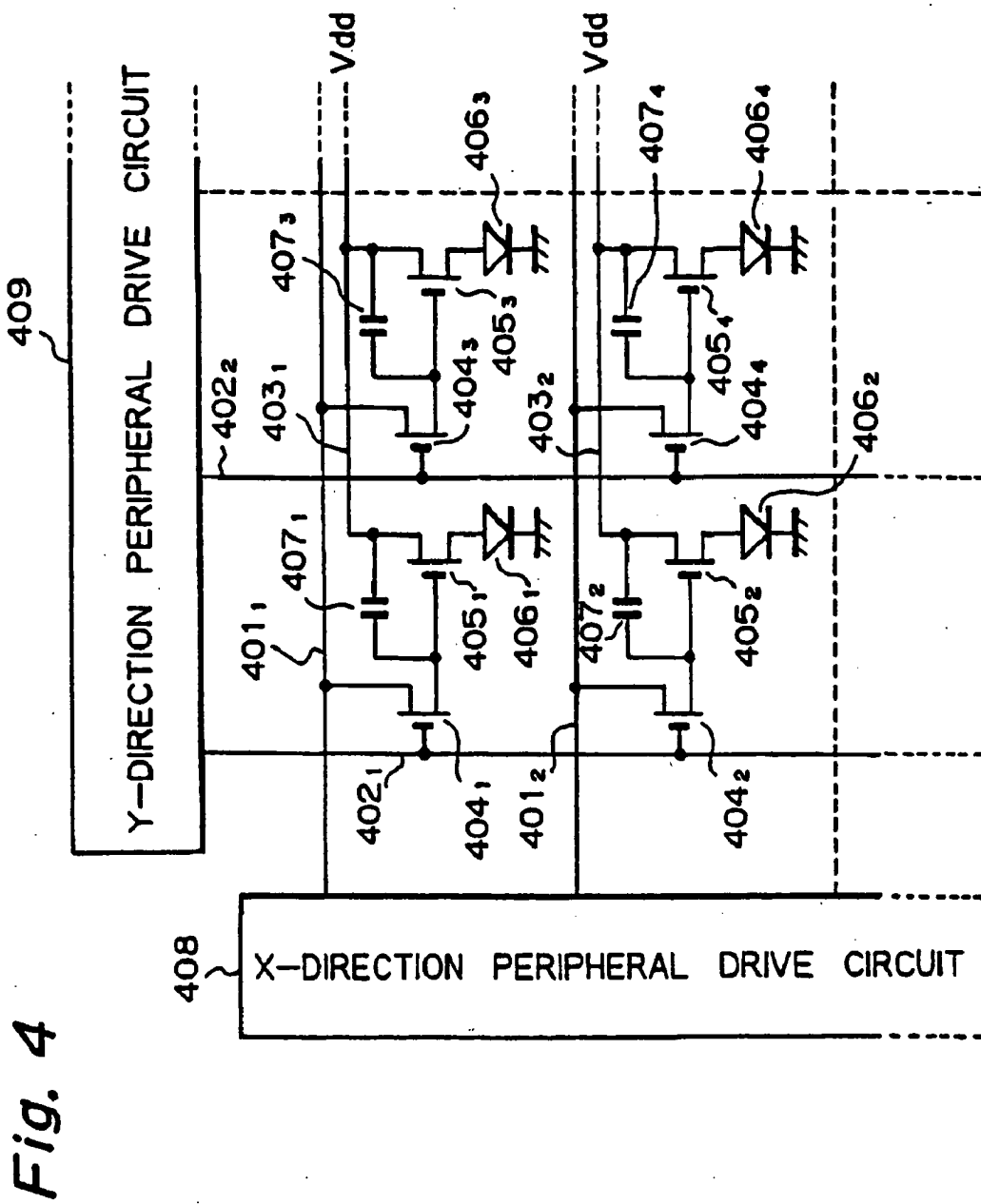

Fig. 2







**THIN FILM TRANSISTOR, ORGANIC
ELECTROLUMINESCENCE DISPLAY DEVICE
AND MANUFACTURING METHOD OF THE SAME**

FIELD OF THE INVENTION

[0001] The present invention relates to a thin film transistor used in an organic electroluminescence (EL) display device, the organic EL display device and a method of manufacturing the organic EL display device.

DESCRIPTION OF THE RELATED ART

[0002] In an organic EL display device, many of organic EL elements are arranged in matrix on a substrate. Each of the EL elements, namely a pixel (picture element), consists of a transparent electrode layer, an organic EL layer and an upper electrode layer. At least one thin film transistor for controlling current applied to the EL element is electrically connected to this EL element.

[0003] In general, each of the thin film transistors has a silicon active layer with a source region and a drain region, and source and drain electrodes of aluminum material to be electrically connected to the source and drain regions, respectively. In the conventional thin film transistor, barrier metal layers made of chrome material are inserted between the silicon active layer and the source and drain electrodes so as to prevent silicon atoms in the silicon active layer from being diffused and disappeared into the source and drain electrodes of aluminum material.

[0004] However, according to the conventional organic EL display device, chrome used for material of the barrier metal layers of the thin film transistors often elutes into the upper electrode layers and the transparent electrode layers of the EL elements causing the thin film transistors to short-circuit with the upper electrode layers or the transparent electrode layers. Subsequently to this, all the chrome of the barrier metal layers may elute so that hollow spaces will be formed between the source and drain regions of the silicon active layers and the aluminum source and drain electrodes. This results disconnection of the source and drain regions and the respective electrodes. These short-circuit and disconnection will stop operations of the thin film transistors causing reliability of the organic EL display device to extremely lower.

SUMMARY OF THE INVENTION

[0005] It is therefore an object of the present invention to provide a thin film transistor used in an organic EL display device, the organic EL display device and a method of manufacturing the organic EL display device, whereby short-circuit and disconnection in the organic EL display device due to elusion of the barrier metal material of the thin film transistors can be prevented from occurring to keep high reliability of the organic EL display device.

[0006] According to careful study by the inventors of this application, it has come out that the aforementioned short-circuit and disconnection are caused by movement of ionized chrome to the organic EL elements. The ionization of the chrome and the movement of the ionized chrome will be occurred due to moisture provided from the organic EL layer made of high hygroscopic material and due to relatively high DC current (bias current) continuously flowing through the

current control thin film transistors connected to the EL elements and through switching thin film transistors connected to and for driving the respective current control transistors.

[0007] Thus, according to the present invention, a thin film transistor which is formed in an organic EL display device having a substrate and a plurality of organic EL elements formed on the substrate is provided. This transistor used to drive one of the EL elements includes an active layer of semiconductor material, formed on the substrate, a source region and a drain region being formed in the active layer, a source electrode of aluminum material electrically coupled to the source region formed in the active layer, a drain electrode of aluminum material electrically coupled to the drain region formed in the active layer, an insulation layer formed on the active layer, a gate electrode formed on the insulation layer, a first barrier metal layer of titanium nitride containing equal to or less than 50 atm % of nitrogen or made of titanium, inserted between the source electrode and the source region of the active layer, and a second barrier metal layer of titanium nitride containing equal to or less than 50 atm % of nitrogen or made of titanium, inserted between the drain electrode and the drain region of the active layer.

[0008] According to the present invention, also, an organic EL display device having a substrate, a plurality of organic EL elements formed on the substrate and a plurality of thin film transistors formed on the substrate is provided. The transistors are connected to the respective EL elements for controlling current applied to the respective elements. Each of the transistors includes an active layer of semiconductor material, formed on the substrate, a source region and a drain region being formed in the active layer, a source electrode of aluminum material electrically coupled to the source region formed in the active layer, a drain electrode of aluminum material electrically coupled to the drain region formed in the active layer, an insulation layer formed on the active layer, a gate electrode formed on the insulation layer, a first barrier metal layer of titanium nitride containing equal to or less than 50 atm % of nitrogen or made of titanium, inserted between the source electrode and the source region of the active layer, and a second barrier metal layer of titanium nitride containing equal to or less than 50 atm % of nitrogen or made of titanium, inserted between the drain electrode and the drain region of the active layer.

[0009] Since the barrier metal layers in the current control thin film transistors arranged nearest to the respective organic EL elements are made of titanium nitride containing equal to or less than 50 atm % of nitrogen or made of titanium, no elusion of the barrier metal layers occurs resulting no short-circuit nor disconnection in the organic EL display device to keep high reliability of the organic EL display device.

[0010] It is preferred that each of the organic EL elements includes a transparent electrode layer formed on the substrate, an organic EL layer formed on the transparent electrode layer and an upper electrode layer formed on the organic EL layer, the transparent electrode being electrically coupled to a conductive lead of aluminum material, and that each of the organic EL elements further includes a contact metal layer of titanium nitride containing equal to or less than 50 atm % of nitrogen or made of titanium, inserted

between the transparent electrode layer and the conductive lead. The above-mentioned conductive lead may be connected to the drain electrode.

[0011] Since both the barrier metal layers in the current control thin film transistors and the contact metal layer in the organic EL elements are simultaneously manufactured in the same process, manufacturing cost can be decreased. Of course, the contact metal layers made of titanium nitride containing equal to or less than 50 atm % of nitrogen or made of titanium will result tight and stable contact between the respective conductive leads of aluminum and the respective transparent electrode layers.

[0012] According to the present invention, furthermore, an organic EL display device of active matrix type having a substrate, a plurality of organic EL elements formed on the substrate and a plurality of first and second thin film transistors formed on the substrate is provided. The first transistors are connected to the respective EL elements for controlling current applied to the respective elements, and the second transistors are connected to the respective first transistors for switching the respective first transistors. Each of the first and second transistors includes an active layer of semiconductor material, formed on the substrate, a source region and a drain region being formed in the active layer, a source electrode of aluminum material electrically coupled to the source region formed in the active layer, a drain electrode of aluminum material electrically coupled to the drain region formed in the active layer, an insulation layer formed on the active layer, a gate electrode formed on the insulation layer, a first barrier metal layer of titanium nitride containing equal to or less than 50 atm % of nitrogen or made of titanium, inserted between the source electrode and the source region of the active layer, and a second barrier metal layer of titanium nitride containing equal to or less than 50 atm % of nitrogen or made of titanium, inserted between the drain electrode and the drain region of the active layer.

[0013] It is preferred that each of the organic EL elements includes a transparent electrode layer formed on the substrate, an organic EL layer formed on the transparent electrode layer and an upper electrode layer formed on the organic EL layer, the transparent electrode being electrically coupled to a conductive lead of aluminum material, and that each of the organic EL elements further includes a contact metal layer of titanium nitride containing equal to or less than 50 atm % of nitrogen or made of titanium, inserted between the transparent electrode layer and the conductive lead. The above-mentioned conductive lead may be connected to the drain electrode.

[0014] According to the present invention, also, a method for manufacturing an organic EL display device having a plurality of organic EL elements and a plurality of thin film transistors formed on a substrate is provided. Each of the organic EL elements and the thin film transistors is manufactured by the steps of depositing an active layer of semiconductor material on the substrate, forming a source region and a drain region in the active layer, forming a gate insulation layer on the active layer, forming a gate electrode on the gate insulation layer, depositing an insulation interlayer on the active layer and the substrate, removing part of the insulation interlayer to form contact holes on the source and drain regions of the active layer and organic EL element

forming region, forming a transparent electrode layer in the organic EL element forming region on the substrate, simultaneously forming first and second barrier metal layers and a contact metal layer of titanium nitride containing equal to or less than 50 atm. % of nitrogen or made of titanium, the first and second barrier metal layers being formed in the contact holes on the source and drain regions of the active layer, the contact metal layer being formed on the transparent electrode layer, forming source and drain electrode and a conductive lead of aluminum material on the first and second barrier metal layers and the contact metal layer, respectively, forming an organic EL layer on the transparent electrode layer, and forming an upper electrode layer on the EL layer.

[0015] Further objects and advantages of the present invention will be apparent from the following description of the preferred embodiments of the invention as illustrated in the accompanying drawings.

BRIEF DESCRIPTION OF THE DRAWINGS

[0016] FIG. 1 shows a sectional view of a part of a preferred embodiment of an organic EL display device according to the present invention;

[0017] FIG. 2 shows a sectional view of a part of the embodiment shown in FIG. 1;

[0018] FIGS. 3a to 3d show sectional views of a part of manufacturing steps of the EL display device according to the embodiment shown in FIG. 1; and

[0019] FIG. 4 shows a circuit diagram of the EL display device shown in FIG. 1.

DESCRIPTION OF THE PREFERRED EMBODIMENTS

[0020] FIG. 1 shows an organic electroluminescence (EL) element and a current control thin film transistor for controlling current applied to the EL element in a preferred embodiment of an organic EL display device according to the present invention.

[0021] In FIG. 1, a reference numeral 101 denotes a transparent substrate such as a quartz substrate. On the substrate 101, many of the organic EL elements and their peripheral circuit elements such as current control thin film transistors, switching thin film transistors for switching the respective current control transistors, another thin film transistors which constitute peripheral driving circuits and capacitors are formed.

[0022] Each of the current control thin film transistors is substantially constituted by an active silicon layer 102 formed on the substrate 101, a gate oxide layer of SiO₂ 103 formed on a central region of the active silicon layer 102, a gate electrode of phosphorous doped Polysilicon 104 laminated on the gate oxide layer 103, a source electrode and conductive lead of aluminum material 113 and a drain electrode and conductive lead of aluminum material 114. The gate electrode 104 can be made of aluminum material instead of the phosphorous doped polysilicon. In the active silicon layer 102, a source region 105, a channel region 106 and a drain region 107 are formed. To the source region 105 of the active silicon layer 102, the source electrode and conductive lead 113 is electrically coupled via a barrier

metal layer of titanium nitride which contains 10 atm % of nitrogen **110**. Also, to the drain region **107** of the active silicon layer **102**, the drain electrode and conductive lead **114** is electrically coupled via a barrier metal layer of titanium nitride which contains 10 atm % of nitrogen **111**. An insulation interlayer of SiO₂ **108** is formed between the active silicon layer **102** and the conductive leads **113** and **114** and between the gate electrode **104** and the barrier metal layers **110** and **111**.

[0023] Each of the organic EL elements is substantially constituted by a transparent electrode layer of ITO (Indium Tin Oxide) **109** formed on the substrate **101**, an organic EL layer **115** formed on the transparent electrode layer **109**, an upper electrode layer of a magnesium film including silver material **116** formed on the EL layer **115** and a common electrode of aluminum material **118** formed on the upper electrode layer **116**. The transparent electrode layer **109** is electrically coupled to the drain conductive lead **114** via a contact metal layer of titanium nitride which contains 10 atm % of nitrogen **112**. A protection layer of SiO₂ **117** is formed between the common electrode **118** and the conductive leads **113** and **114**.

[0024] FIG. 2 shows the switching thin film transistor in the preferred embodiment of the organic EL display device according to the present invention.

[0025] Each of the switching thin film transistors is substantially constituted by an active silicon layer **202** formed on the substrate **101**, a gate oxide layer of SiO₂ **203** formed on a central region of the active silicon layer **202**, a gate electrode of phosphorous doped polysilicon **204** laminated on the gate oxide layer **203**, a source electrode and conductive lead of aluminum material **213** and a drain electrode and conductive lead of aluminum material **214**. The gate electrode **204** can be made of aluminum material instead of the phosphorous doped polysilicon. In the active silicon layer **202**, a source region **205**, a channel region **206** and a drain region **207** are formed. To the source region **205** of the active silicon layer **202**, the source electrode and conductive lead **213** is electrically coupled via a barrier metal layer of titanium nitride which contains 10 atm % of nitrogen **210**. Also, to the drain region **207** of the active silicon layer **202**, the drain electrode and conductive lead **214** is electrically coupled via a barrier metal layer of titanium nitride which contains 10 atm % of nitrogen **211**. An insulation interlayer of SiO₂ **208** is formed between the active silicon layer **202** and the conductive leads **213** and **214** and between the gate electrode **204** and the barrier metal layers **210** and **211**.

[0026] Referring to FIGS. 3a to 3d, manufacturing processes of the current control thin film transistor and the organic EL element of this embodiment will be described in detail. It should be noted that manufacturing processes of the switching thin film transistor and another thin film transistors which constitute peripheral driving circuits of the EL element will be the same as following processes of the current control thin film transistor.

[0027] As shown in FIG. 3a, on a transparent substrate **101** such as a quartz substrate, a glass substrate or a ceramic substrate, an active silicon layer **102** with an island shape is formed by depositing an amorphous silicon layer by a CVD (Chemical Vapor Deposition) method, annealing the deposited amorphous silicon layer to form a polysilicon layer (solid-phase growth), and then performing patterning process of the polysilicon layer.

[0028] Then, on the active silicon layer **102**, a gate oxide layer of SiO₂ **103** and a gate electrode of phosphorous doped polysilicon **104** are formed in lamination. The gate electrode **104** can be made of aluminum material instead of the phosphorous doped polysilicon. Thereafter, a source region **105**, a channel region **106** and a drain region **107** are formed in the active silicon layer **102** by an Ion doping method. In this embodiment, dopant is for example P and the gate electrode **104** is used as a mask for the doping process. Then, to cover all of these layers, an insulation interlayer of SiO₂ **108** is deposited.

[0029] Then, contact holes are formed by etching the insulation interlayer **108** at the source region **105** and at the drain region **107**. Also, by this etching process, the insulation interlayer **108** in a region for forming the EL element is removed.

[0030] Then, a transparent conductive film of ITO, ZnO or SnO is sputtered to form a transparent electrode layer **109** in the EL element forming region on the substrate **101**. Without removing the insulation interlayer **108** from the EL element forming region, the transparent electrode layer may be formed on this insulation interlayer **108** not directly on the substrate **101**. Thereafter, a titanium nitride film consisting nitrogen of 10 atm % with a thickness of 100 to 1000 Angstrom preferably 500 Angstrom is deposited on all of these layers. Then, this deposited titanium nitride film is etched to simultaneously form a barrier metal layer of titanium nitride **110** on the source region **105**, a barrier metal layer of titanium nitride **111** on the drain region **107** and a contact metal layer of titanium nitride **112** on the transparent electrode layer **109**, respectively.

[0031] It will be apparent that barrier metal layers of titanium nitride in the switching thin film transistor and in the another thin film transistors which constitute peripheral driving circuits of the EL element can be simultaneously formed in this process.

[0032] Then, as shown in FIG. 3c, an aluminum film with a thickness of 6000 Angstrom is deposited by for example sputtering to cover all of these layers and the deposited aluminum film is etched so as to form a source electrode and conductive lead **113** and a drain electrode and conductive lead **114**. Thus, the source electrode and conductive lead of aluminum **113** is electrically coupled to the source region **105** of the active silicon layer **102** via the barrier metal layer of titanium nitride **110**, and also, the drain electrode and conductive lead of aluminum **114** is electrically coupled to the drain region **107** of the active silicon layer **102** via the barrier metal layer of titanium nitride **111** and to the transparent electrode layer **109** via the contact metal layer of titanium nitride **112**.

[0033] Then, as shown in FIG. 3d, an organic EL layer **115** and an upper electrode layer of a magnesium film including silver material **116** are formed in the EL element forming region on the transparent electrode layer **109** by vapor deposition methods using a metal mask. Thereafter, on these layers, a protection layer of SiO₂ **117** is deposited and a contact hole is etched on the upper electrode layer **116**. Finally, a common electrode of aluminum material **118** is deposited on all of the matrix portion of the organic EL display device.

[0034] In the aforementioned embodiment, it is described that the barrier metal layers **110** and **111** and the contact

metal layer **112** are made of titanium nitride containing 10 atm % of nitrogen. Higher containing amount of nitrogen in the titanium nitride material will increase degree of contact and stability but decrease electrical conductivity. Thus, according to the present invention, this containing amount of nitrogen in the titanium nitride material is selected to a value equal to or less than 50 atm % preferably 5 to 15 atm % for obtaining both good stability and electrical conductivity.

[0035] According to the present invention, since the barrier metal layers in the current control thin film transistors arranged nearest to the respective organic EL elements are made of titanium nitride containing equal to or less than 50 atm % of nitrogen, no elusion of the barrier metal layers occurs resulting no short-circuit nor disconnection in the organic EL display device to keep high reliability of the organic EL display device. Furthermore, since both the barrier metal layers in the current control thin film transistors and the contact metal layer in the organic EL elements are simultaneously manufactured in the same process, manufacturing cost can be decreased. Of course, the contact metal layers of titanium nitride containing equal to or less than 50 atm % of nitrogen will result tight and stable contact between the respective conductive leads of aluminum and the respective transparent electrode layers.

[0036] According to the present invention, also, the barrier metal layers in the current control thin film transistors and the contact metal layers in the respective organic EL elements can be made of titanium. Thus, no elusion of the barrier metal layers occurs resulting no short-circuit nor disconnection in the organic EL display device to keep high reliability of the organic EL display device. Furthermore, if both the barrier metal layers in the current control thin film transistors and the contact metal layer in the organic EL elements can be simultaneously manufactured in the same process, manufacturing cost can be decreased. Of course, the contact metal layers of titanium will also result tight and stable contact between the respective conductive leads of aluminum and the respective transparent electrode layers.

[0037] As shown in **FIG. 4**, the organic EL display device according to the embodiment shown in **FIG. 1** is constituted by X-direction signal lines **401₁**, **401₂**, . . . , Y-direction signal lines **402₁**, **402₂**, . . . , power supply lines (Vdd) **403₁**, **403₂**, . . . , switching thin film transistors **404₁**, **404₂**, **404₃**, **404₄**, . . . , current control thin film transistors **405₁**, **405₂**, **405₃**, **405₄**, . . . , organic EL elements **406₁**, **406₂**, **406₃**, **406₄**, . . . , capacitors **407₁**, **407₂**, **407₃**, **407₄**, . . . , a X-direction peripheral drive circuit **408** and a Y-direction peripheral drive circuit **409**.

[0038] Each of the pixels of the EL display device is specified by one of the X-direction signal lines **401₁**, **401₂**, . . . and one of the Y-direction signal lines **402₁**, **402₂**, If a signal corresponding to picture data is applied to the X-direction signal line **401₂** and Y-direction scanning signal is applied to the Y-direction signal line **402₁**, the switching transistor **404₂** in the specified pixel turns on. Thus, the current control transistor **405₂** controls current flowing from the power supply line **403₂** into the organic EL element **406₂** in accordance with the picture data causing corresponding light emission from this EL element **406₂**.

[0039] According to the present invention, at least the barrier metal layers in the current control thin film transistors and preferably the barrier metal layers in the switching

thin film transistors are made of titanium nitride containing equal to or less than 50 atm % of nitrogen or made of titanium. In manufacturing the EL display device, it is desired that the contact metal layers in the organic EL elements are simultaneously formed in the same process of the barrier metal layers with the same material, namely titanium nitride containing equal to or less than 50 atm % of nitrogen or titanium. Furthermore, according to the present invention, the barrier metal layers in the thin film transistors in the peripheral drive circuits are preferably made of titanium nitride containing equal to or less than 50 atm % of nitrogen or made of titanium.

[0040] Many widely different embodiments of the present invention may be constructed without departing from the spirit and scope of the present invention. It should be understood that the present invention is not limited to the specific embodiments described in the specification, except as defined in the appended claims.

What is claimed is:

1. An electroluminescence display device comprising:

a substrate;

a first thin transistor disposed over said substrate, said first thin film transistor comprising source, drain and channel regions and a gate electrode adjacent to the channel region;

a second thin film transistor disposed over said substrate and electrically connected to said first thin film transistor, said second thin film transistor comprising source, drain and channel regions and a gate electrode adjacent to the channel region;

an electroluminescence element electrically connected to said second thin film transistor, said electroluminescence element comprising:

a transparent first electrode comprising zinc oxide;

an electroluminescence layer formed over the transparent first electrode; and

a second electrode formed over the electroluminescence layer.

2. The electroluminescence display device according to claim 1 wherein the channel regions of said first and second thin film transistors comprise polysilicon.

3. The electroluminescence display device according to claim 1 wherein one of the source and drain regions of the first thin film transistor is electrically connected to the gate electrode of the second thin film transistor.

4. An electroluminescence display device comprising:

a substrate;

a first thin transistor disposed over said substrate, said first thin film transistor having an active layer comprising source, drain and channel regions;

a second thin film transistor disposed over said substrate and electrically connected to said first thin film transistor, said second thin film transistor having an active layer comprising source, drain and channel regions;

a transparent first electrode comprising zinc oxide electrically connected to said second thin film transistor through a conductive layer comprising aluminum;

an electroluminescence layer formed over the transparent first electrode;

a second electrode formed over the electroluminescence layer; and

a barrier metal layer between the transparent first electrode and the conductive layer comprising aluminum to prevent a direct contact therebetween.

5. The electroluminescence display device according to claim 4 wherein said barrier metal layer is formed on and in contact with an upper surface and a side surface of said transparent first electrode.

6. The electroluminescence display device according to claim 4 wherein said barrier metal layer comprises titanium nitride with a concentration of nitrogen being equal to or less than 50 atm %.

7. The electroluminescence display device according to claim 4 further comprising a second barrier metal layer between the conductive layer and the active layer of the second thin film transistor to prevent a direct contact therebetween.

8. The electroluminescence display device according to claim 4 wherein the active layers of said first and second thin film transistors comprise polysilicon.

9. The electroluminescence display device according to claim 4 further comprising a peripheral driving circuit which comprises a third thin film transistor formed over said substrate.

10. An electroluminescence display device comprising:

a substrate;

a first thin transistor disposed over said substrate, said first thin film transistor having an active layer comprising source, drain and channel regions;

a second thin film transistor disposed over said substrate and electrically connected to said first thin film transistor, said second thin film transistor having an active layer comprising source, drain and channel regions;

a transparent first electrode comprising zinc oxide electrically connected to said second thin film transistor through a conductive layer comprising aluminum;

an electroluminescence layer formed over the transparent first electrode;

a second electrode formed over the electroluminescence layer; and

a barrier metal layer between the conductive layer comprising aluminum and the active layer of the second thin film transistor to prevent a direct contact therebetween.

11. The electroluminescence display device according to claim 10 wherein said barrier metal layer comprises titanium nitride with a concentration of nitrogen being equal to or less than 50 atm %.

12. The electroluminescence display device according to claim 10 wherein the active layers of said first and second thin film transistors comprise polysilicon.

13. The electroluminescence display device according to claim 10 further comprising a peripheral driving circuit which comprises a third thin film transistor formed over said substrate.

14. An electroluminescence display device comprising:

a substrate;

a first thin transistor disposed over said substrate, said first thin film transistor comprising source, drain and channel regions and a gate electrode adjacent to the channel region;

a second thin film transistor disposed over said substrate and electrically connected to said first thin film transistor, said second thin film transistor comprising source, drain and channel regions and a gate electrode adjacent to the channel region;

an electroluminescence element electrically connected to said second thin film transistor, said electroluminescence element comprising:

a transparent first electrode comprising zinc oxide;

an electroluminescence layer formed over the transparent first electrode; and

a second electrode formed over the electroluminescence layer; and

a peripheral driving circuit comprising a third thin film transistor formed over said substrate, said third thin film transistor comprising source, drain and channel regions.

15. The electroluminescence display device according to claim 14 wherein the channel regions of said first, second and third thin film transistors comprise polysilicon.

16. The electroluminescence display device according to claim 14 wherein one of the source and drain regions of the first thin film transistor is electrically connected to the gate electrode of the second thin film transistor.

17. An electroluminescence display device comprising:

a substrate;

a first thin transistor disposed over said substrate, said first thin film transistor having an active layer comprising source, drain and channel regions;

a second thin film transistor disposed over said substrate and electrically connected to said first thin film transistor, said second thin film transistor having an active layer comprising source, drain and channel regions;

a transparent first electrode electrically connected to said second thin film transistor through a conductive layer comprising aluminum;

an electroluminescence layer formed over the transparent first electrode;

a second electrode formed over the electroluminescence layer; and

a barrier metal layer between the transparent first electrode and the conductive layer comprising aluminum to prevent a direct contact therebetween,

wherein said barrier metal layer is formed on and in contact with an upper surface and a side surface of said transparent first electrode.

18. The electroluminescence display device according to claim 17 wherein said barrier metal layer comprises titanium nitride with a concentration of nitrogen being equal to or less than 50 atm %.

19. The electroluminescence display device according to claim 17 further comprising a second barrier metal layer between the conductive layer and the active layer of the second thin film transistor to prevent a direct contact therebetween.

20. The electroluminescence display device according to claim 17 wherein the active layers of said first and second thin film transistors comprise polysilicon.

* * * * *

专利名称(译)	薄膜晶体管，有机电致发光显示装置及其制造方法		
公开(公告)号	US20050146262A1	公开(公告)日	2005-07-07
申请号	US11/041702	申请日	2005-01-25
[标]申请(专利权)人(译)	株式会社半导体能源研究所		
申请(专利权)人(译)	半导体能源研究所有限公司. TDK株式会社		
当前申请(专利权)人(译)	半导体能源研究所有限公司. TDK株式会社		
[标]发明人	YAMAUCHI YUKIO ARAI MICHIO		
发明人	YAMAUCHI, YUKIO ARAI, MICHIO		
IPC分类号	G09G3/32 H01L27/32 H05B33/06 H05B33/12 H05B33/00 H05B33/04 H05B33/08		
CPC分类号	G09G3/3233 G09G2300/0842 H01L27/12 H01L27/124 H05B33/06 H05B33/12 H01L27/3248		
优先权	1995065943 1995-03-24 JP		
其他公开文献	US6992435		
外部链接	Espacenet USPTO		

摘要(译)

有机EL显示装置具有基板，形成在基板上的多个有机EL元件和形成在基板上的多个薄膜晶体管。晶体管连接到相应的EL元件，用于控制施加到各个元件的电流。每个晶体管包括形成在基板上的半导体材料的有源层，形成在有源层中的源区和漏区，电耦合到形成在有源层中的源区的铝材料的源电极，铝电极的漏电极电耦合到形成在有源层中的漏区，形成在有源层上的绝缘层，形成在绝缘层上的栅电极，含有等于或小于50的氮化钛的第一阻挡金属层插入在有源层的源电极和源区之间的氮或钛的atm%，和插入在漏电极和之间的氮或钛的等于或小于50atm%的氮化钛的第二阻挡金属层。有源层的漏极区域。

